



# THE HALF PINT OD MOBILE DEPALLETIZER

The Half Pint OD (Orbital Discharge) mobile depalletizer is designed for mobile canners and breweries with tight space restrictions. The first-of-its-kind rotary design features a 30-inch wheel, allowing for more accumulation, higher line speeds, a smaller footprint, and a better drop angle for the rinse cage. The wheel can run clockwise or counter-clockwise, making it possible to install two discharges for different can sizes with little to no changeover. With no vibrator, this machine is essentially silent. There is no installation required, making it a great option for small breweries and international locations.



## STANDARD FEATURES:

- Patent-pending rotary design featuring 30" wheel
- Stainless steel and lightweight aluminum construction
- Speeds from 10 CPM up to 80 CPM
- Minimal air consumption (<1 CFM @30 PSI) (<.03cmm @ 2 Bar)
- 120V or 220V single phase
- Can accommodate multiple can sizes with little to no changeover
- Removable gates allow over 180 degrees of flexibility for discharge and rinse cage placement
- Fully automated once pallet is inserted into the machine & the straps & tier frame are removed
- Lightweight with wheels for easy movement
- Includes one rinse cage, tool box & storage area
- Takes half pallets of aluminum and metal containers
- Designed for low clearance applications such as box trucks or low ceiling heights
- Optional CE certification

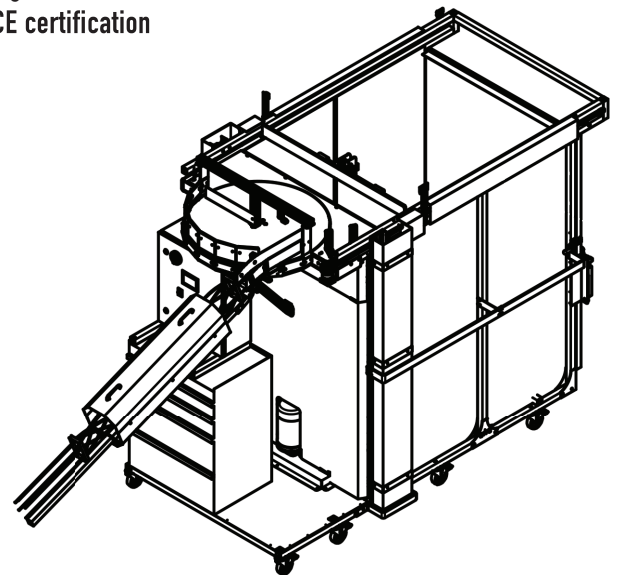
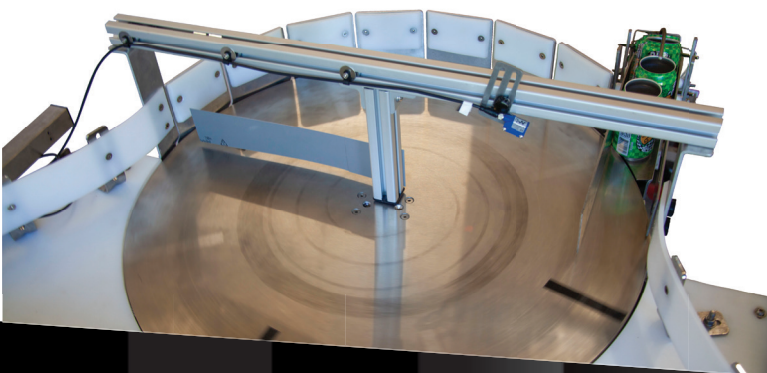

WWW.SKAFABRICATING.COM  
(970) 403-8562  
sales@skafabricating.com

© Ska Fabricating 2019